

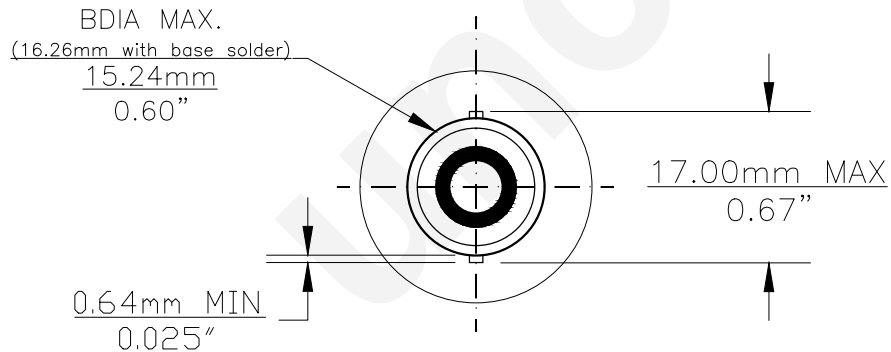

PART NO.	BASE TYPE	DESIGN VOLTS	DESIGN AMPS	MSCD	FILAMENT TYPE	AVERAGE LIFE HOURS	REVISIONS			
							REV #	DESCRIPTION	DATE	APPROVED
1156NALL	S.C. Bayonet (BA15s)	12.8V	2.10 ±5%	24 ±30%	C-6	2000	1	ISSUED	07/01/2009	D.C.

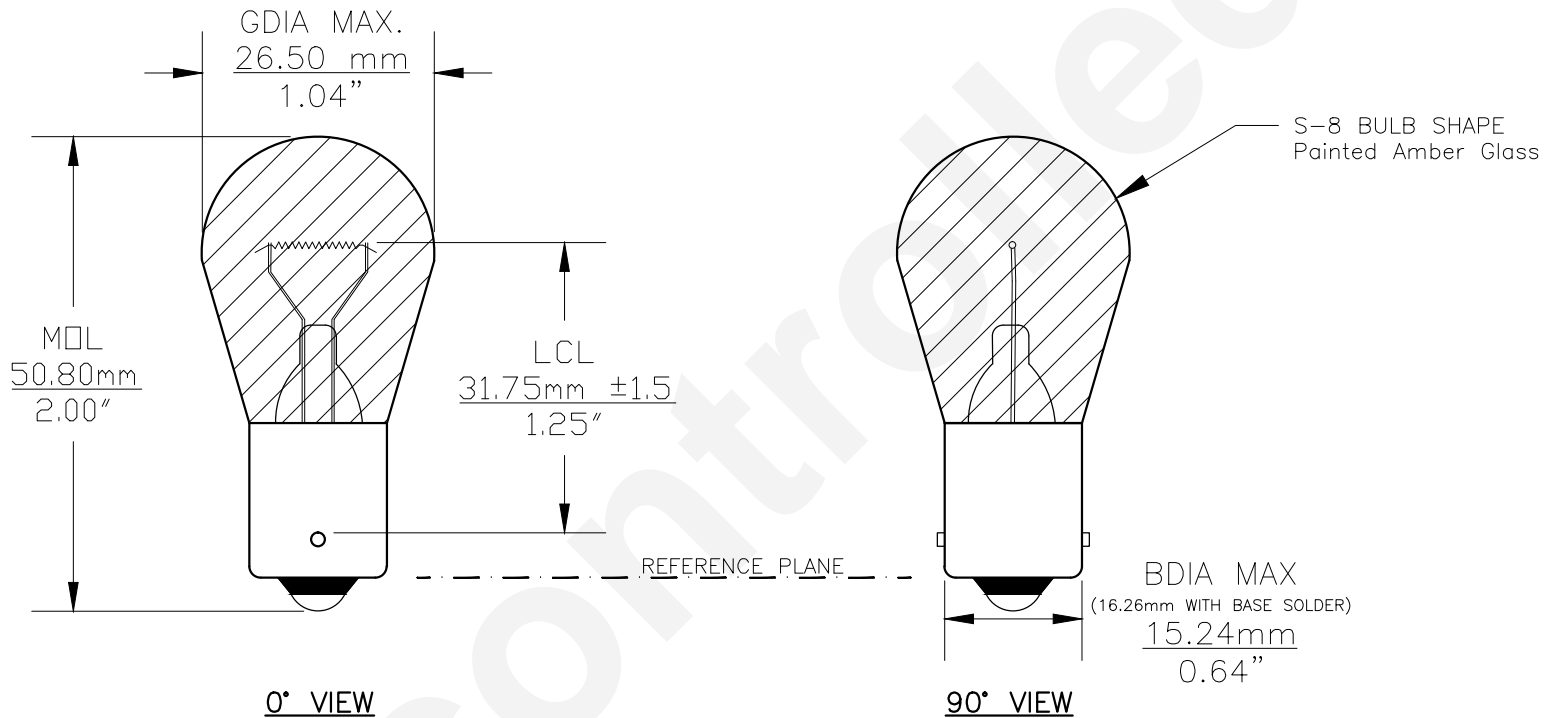

Note: Made according to SAE specifications



UNLESS OTHERWISE SPECIFIED: DIMENSIONS ARE IN INCHES TOLERANCES		CEC INDUSTRIES LTD			
DECIMALS	ANGULAR	599 BOND STREET		LINCOLNSHIRE, IL 60069	
.XX ± .05	± 0.5°	TITLE LIGHT BULB NO. 1156NALL			
.XXX ± .010		SIZE A	FSCM NO.	DWG NO. 1156NALL	REV 1
FRACTIONAL	±1/64	DESIGN	SCALE	PLOT SCALE	SHEET 1 OF 1
DRAWN D. C.		DATE 07/01/2009	MATERIAL		
CHECKED		FILE 1156NALL.pdf	DRAWING NOT TO SCALE		