

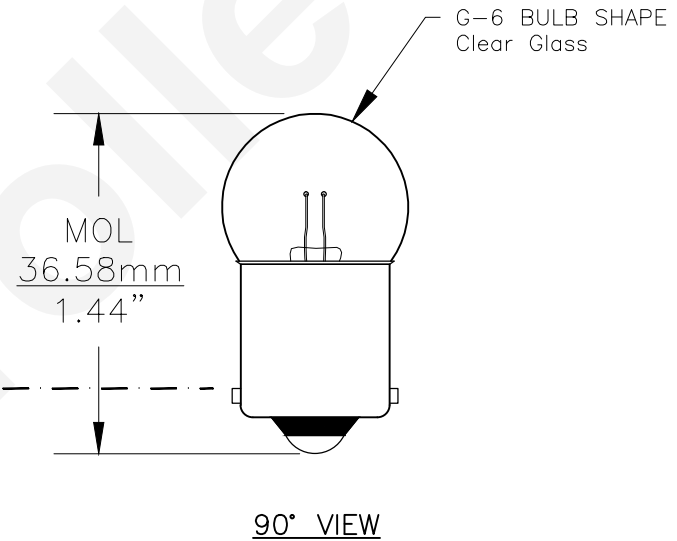

PART NO.	BASE TYPE	DESIGN VOLTS	DESIGN AMPS	MSCD	FILAMENT TYPE	AVERAGE LIFE HOURS	REVISIONS			
							REV #	DESCRIPTION	DATE	APPROVED
1247	S.C. BAYONET (BA15s)	14.0V	0.43±20%	3 ±20%	2C-6	1000	1	ISSUED	11/03/2014	R.M.

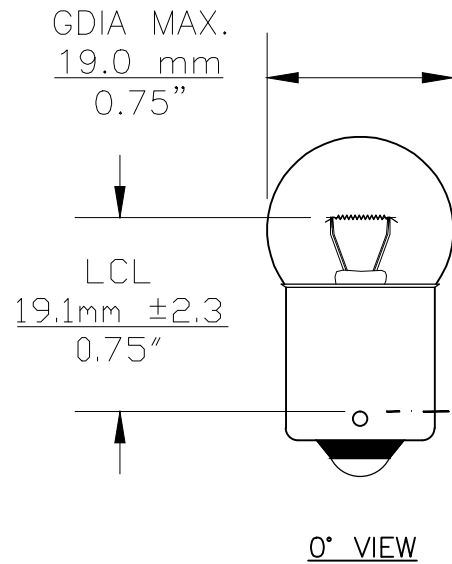

REFERENCE PLANE

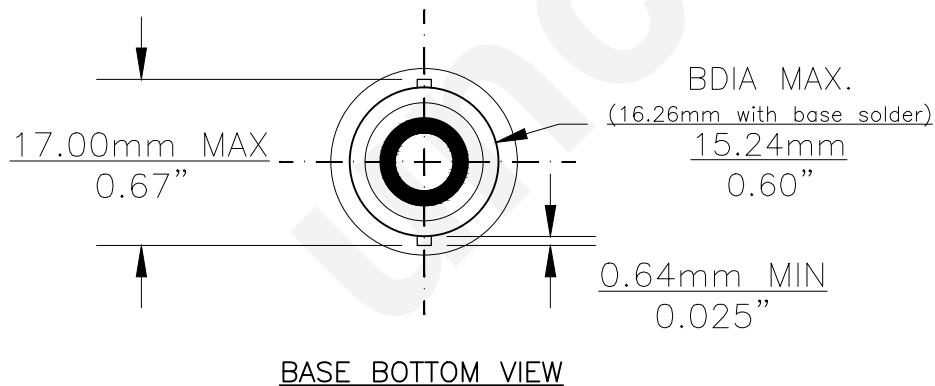

Note: Made according to SAE specifications

UNLESS OTHERWISE SPECIFIED: DIMENSIONS ARE IN INCHES TOLERANCES		CEC INDUSTRIES LTD			
DECIMALS .XX ± .05	ANGULAR ± 0.5°	599 BOND STREET		LINCOLNSHIRE, IL 60069	
.XXX ± .010	FRACTIONAL ± 1/64	TITLE LIGHT BULB NO. 1247			
DRAWN ROSE MEDINA	DATE 11/03/2014	SIZE A	FSCM NO.	DWG NO. 1247	REV 1
DESIGN	SCALE	PLOT SCALE	SHEET 1 OF 1		
MATERIAL	FILE 1247.pdf	DRAWING NOT TO SCALE			