

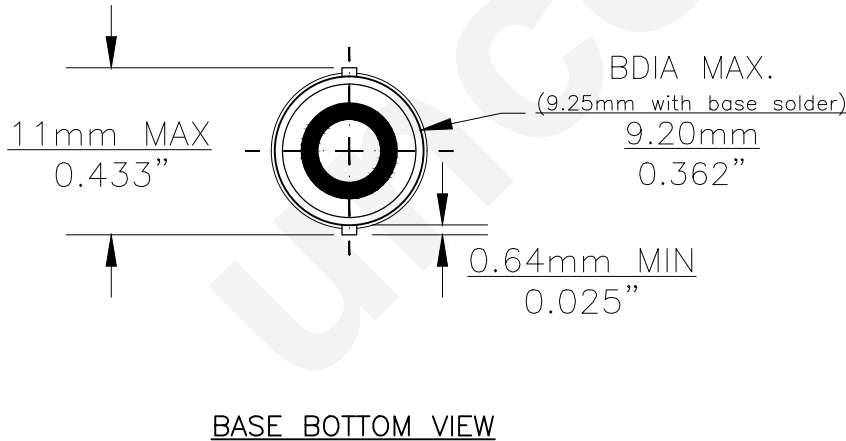

PART NO.	BASE TYPE	DESIGN VOLTS	DESIGN AMPS	MSCD	FILAMENT TYPE	AVERAGE LIFE HOURS	REVISIONS			
							REV #	DESCRIPTION	DATE	APPROVED
130V/MB	MINIATURE BAYONET (BA9s)	130.0V	0.018±20%	0.20±20%	CC-7A	2000	1	ISSUED	05/22/2009	D.C.
							2	ISSUED	08/27/2013	D.C.
							3	REDRAWN FOR ADDITIONAL VIEWS	07/03/2014	R.M.

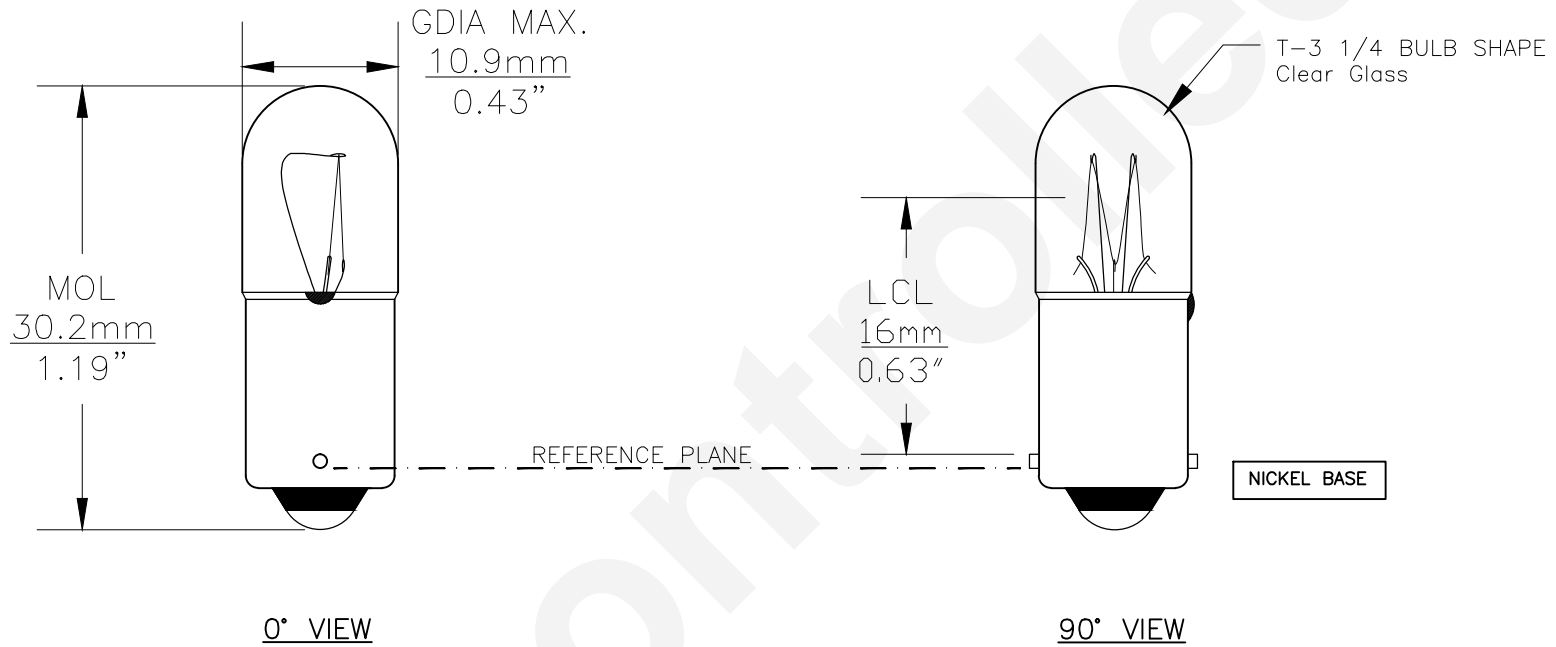

Note: Made according to SAE specifications

UNLESS OTHERWISE SPECIFIED: DIMENSIONS ARE IN INCHES TOLERANCES		CEC INDUSTRIES LTD			
DECIMALS .XX ± .05		599 BOND STREET		LINCOLNSHIRE, IL 60069	
ANGULAR .XXX ± .010		TITLE LIGHT BULB NO. 130V/MB			
FRACTIONAL ±1/64		DATE 05/22/2009		REV 3	
DRAWN D.C.		SIZE A	FSCM NO.	DWG NO. 130V/MB	REV 3
CHECKED		SCALE	PLOT SCALE	SHEET 1 OF 1	
DESIGN		FILE 130VMB.pdf		DRAWING NOT TO SCALE	
MATERIAL					