

PART NO.	BASE TYPE	DESIGN VOLTS	DESIGN WATTS	LUMENS	FLUORESCENT TYPE	AVERAGE LIFE HOURS
15T7N-120V	INTERMEDIATE SCREW E17	120	15	108	C-7A	1000

REVISIONS			
REV	DESCRIPTION	DATE	APPROVED
1	ISSUED	06/15/2007	D.C.

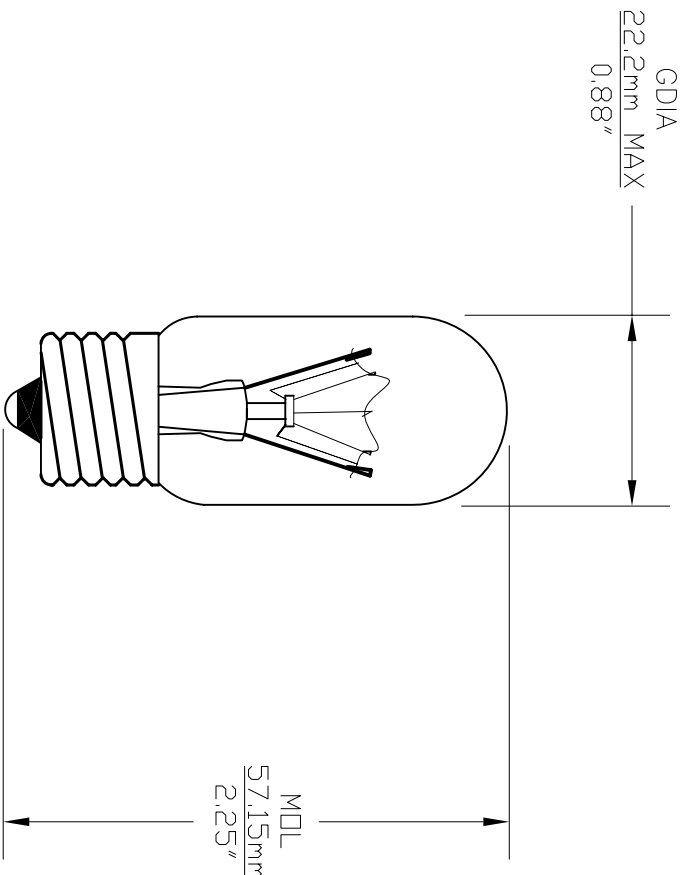

UNLESS OTHERWISE SPECIFIED: DIMENSIONS ARE IN INCHES TOLERANCES DECIMALS .XX ± .05 .XXX ± .010 FRACTIONAL ± 1/64		DATE 06/15/2007	
DRAWN D.C.		TITLE 599 BOND STREET <b>CEC INDUSTRIES LTD</b> LINCOLNSHIRE, IL 60069	
CHECKED		SIZE A	FSCM NO.
DESIGN		SCALE	DWG NO. 15T7N-120V
MATERIAL		PLOT SCALE	SHEET 1 OF 1
FILE 15T7N-120V.dwg		DO NOT SCALE DRAWING	
REV 1		REV 1	