

PART NO.	BASE TYPE	DESIGN VOLTS	DESIGN WATTS	FINISH	FILAMENT TYPE	AVERAGE LIFE HOURS
6418	FESTOON SV8.5-8	12	5	CLEAR	C-8	300

REVISIONS			
REV	DESCRIPTION	DATE	APPROVED
1	ISSUED	10/31/2008	D.C.
2	REVISED MSCP, ADDED TEST SPEC.	09/11/2012	D.C.

BULB TYPE: C5W, T11X37,  
T3-1/4

TEST VOLTAGE: 13.5V, 5W±10%, 45 LUMENS ±20% (3.6MSCP)

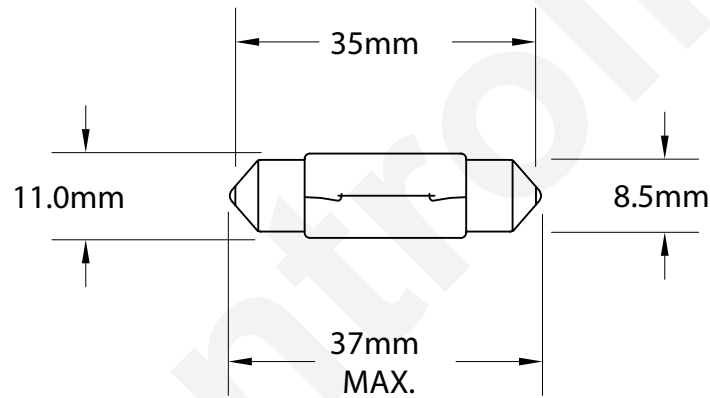

BASE MARKING: 6418

UNLESS OTHERWISE SPECIFIED: DIMENSIONS ARE IN MM		<b>CEC INDUSTRIES LTD</b>			
TOLERANCES		599 BOND STREET LINCOLNSHIRE, IL 60069			
DECIMALS	ANGULAR	TITLE			
.XX ± .05	± 0.5°	LIGHT BULB NO. 6418			
.XXX ± .010		DRAWN		DATE	
FRACTIONAL	+1/64	D.C.	10/31/2008		
CHECKED		SIZE	FSCM NO.	DWG NO.	REV
DESIGN				6418	2
MATERIAL		SCALE	PLOT SCALE	SHEET 1 OF 1	
		FILE 6418.dwg	DO NOT SCALE DRAWING		