

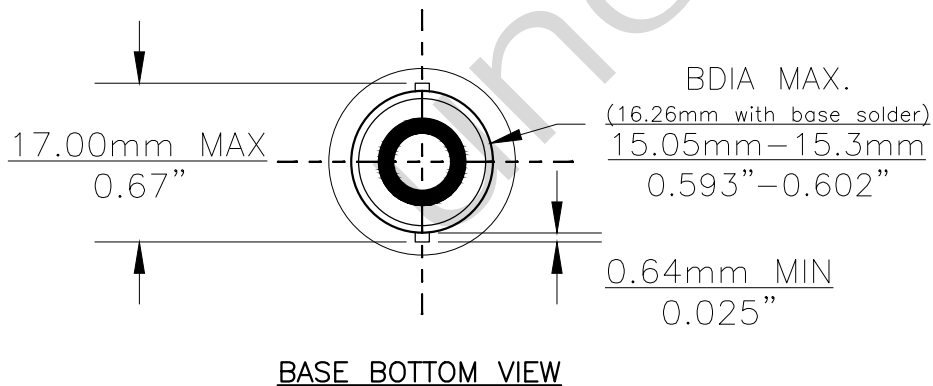

Since 1959

PART NO.	BASE TYPE	DESIGN VOLTS	DESIGN AMPS	MSCD	FILAMENT TYPE	AVERAGE LIFE HOURS	REVISIONS			
							REV #	DESCRIPTION	DATE	APPROVED
67NA	S.C. BAYONET (BA15s)	13.5V	0.59 ±8%	3 ±15%	C-6	5000	1	ISSUED	05/29/2014	R.M.

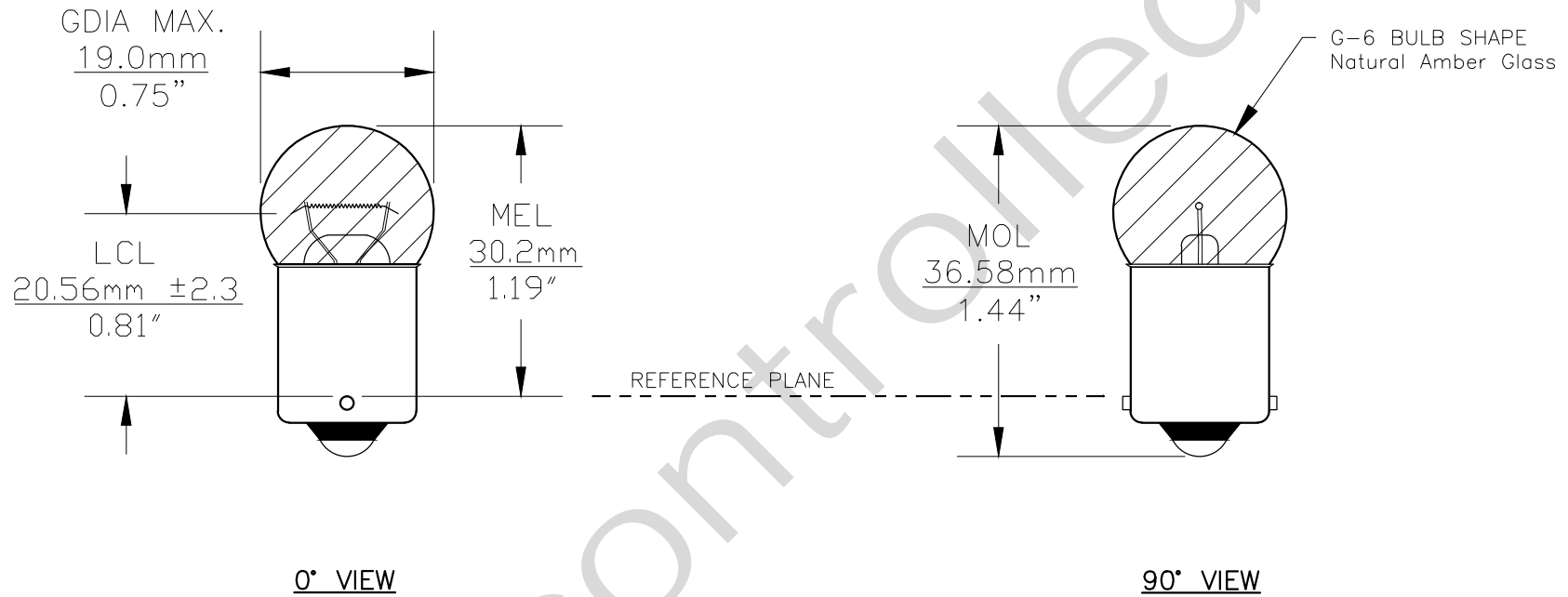

Note: Made according to SAE specifications

UNLESS OTHERWISE SPECIFIED: DIMENSIONS ARE IN INCHES TOLERANCES		CEC INDUSTRIES LTD			
DECIMALS .XX ± .05		599 BOND STREET		LINCOLNSHIRE, IL 60069	
ANGULAR .XXX ± .010		TITLE LIGHT BULB NO. 67NA			
FRACTIONAL ±1/64		DATE 05/29/2014	SIZE A	DWG NO. 67NA	REV 1
DRAWN ROSE MEDINA		SCALE	PLOT SCALE	SHEET 1 OF 1	
CHECKED		FILE 67NA.pdf	DRAWING NOT TO SCALE		