

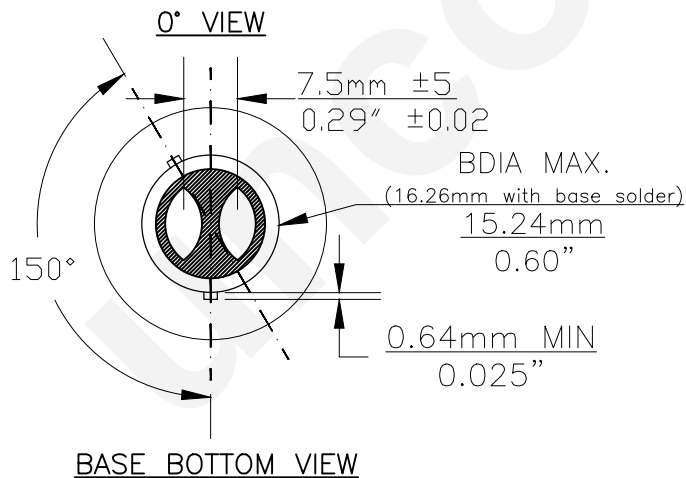

PART NO.	BASE TYPE	DESIGN VOLTS	DESIGN AMPS	MSCD	FILAMENT TYPE	AVERAGE LIFE HOURS
7225LL	D.C. INDEX (BAZ15d)	12.8V 12V	35 ±10% 1.20 ±10%	35±15% 1.20±20%	C-6 C-6	400 2000

REVISIONS			
REV #	DESCRIPTION	DATE	APPROVED
1	ISSUED	07/07/2009	D.C.

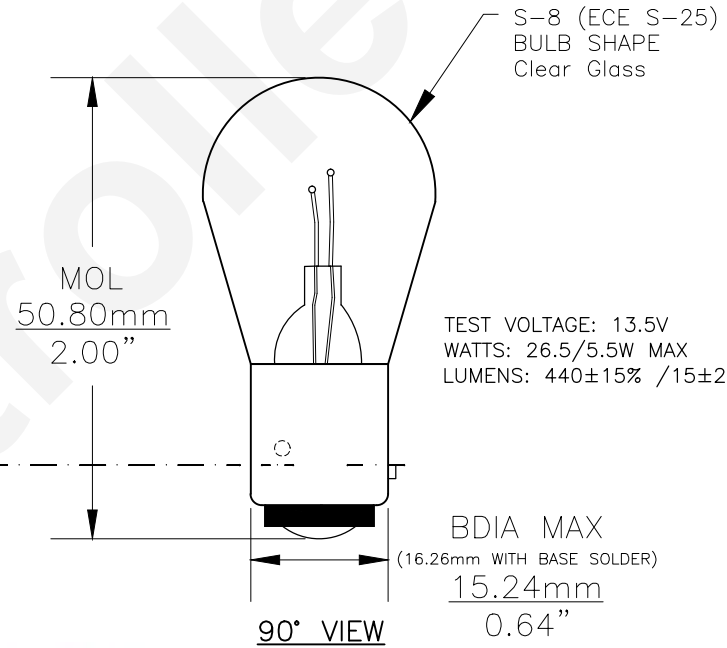
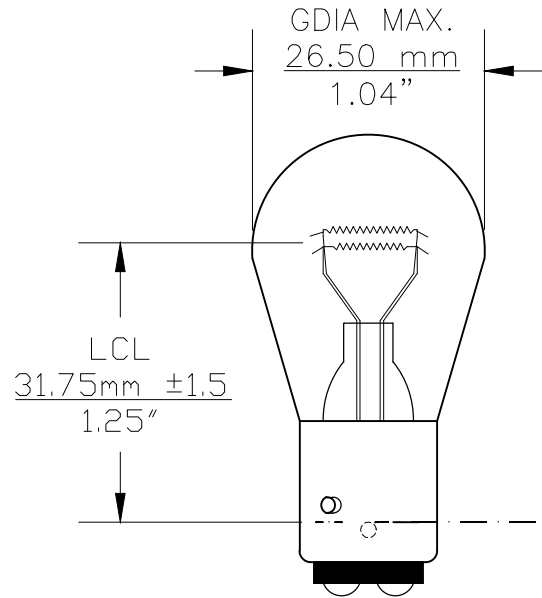

Note: Made according to ECE/R37 specifications

UNLESS OTHERWISE SPECIFIED: DIMENSIONS ARE IN INCHES TOLERANCES		CEC INDUSTRIES LTD	
DECIMALS .XX ± .05	ANGULAR .XXX ± .010	599 BOND STREET	LINCOLNSHIRE, IL 60069
FRACTIONAL ±1/64		TITLE LIGHT BULB NO. 7225LL	
DRAWN ROSE MEDINA	DATE 05/27/2014	SIZE A	FSCM NO. 7225LL
CHECKED		DWG NO. 7225LL	REV 2
DESIGN	SCALE	PLOT SCALE	SHEET 1 OF 1
MATERIAL	FILE 7225LL.pdf	DRAWING NOT TO SCALE	