

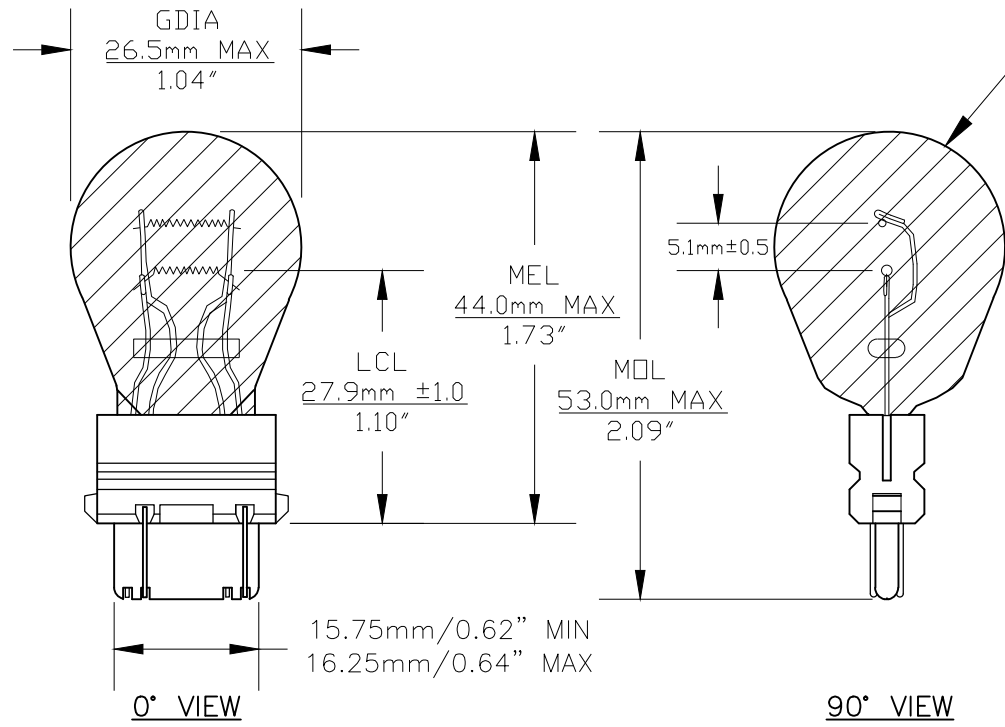

Since 1959

PART NO.	BASE TYPE	DESIGN VOLTS	DESIGN AMPS	MSCD	FILAMENT TYPE	AVERAGE LIFE HOURS	REVISIONS			
							REV #	DESCRIPTION	DATE	APPROVED
HIB3457 WM	D.F. Plastic Wedge W2.5X16q	12.8V 14.0V	2.23±5% 0.59±8%	40±10% 3±12%	C-6 C-6	400 5000	1	ISSUED	05/02/2019	R.M.



S-8 BULB SHAPE  
Blue Coating

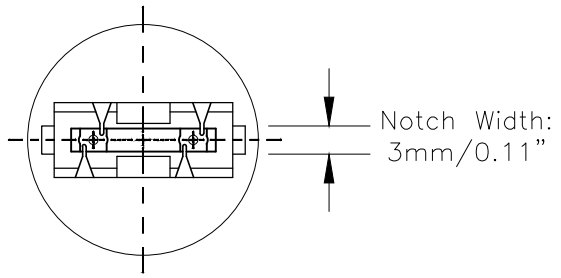
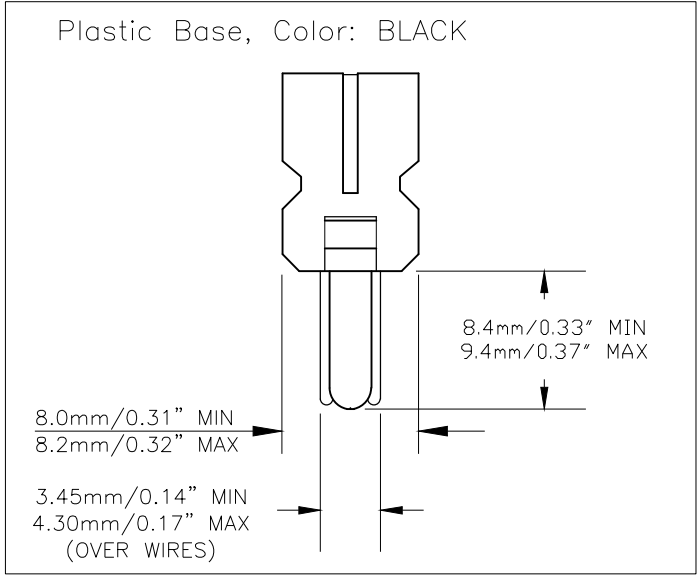

BASE BOTTOM VIEW

BASE SIDE VIEW

Note: Made according to SAE specifications



UNLESS OTHERWISE SPECIFIED: DIMENSIONS ARE IN INCHES TOLERANCES		CEC INDUSTRIES LTD			
DECIMALS	ANGULAR	599 BOND STREET		LINCOLNSHIRE, IL 60069	
.XX ± .05	± 0.5°	TITLE LIGHT BULB NO. HIB3457 WM			
.XXX ± .010		DATE	05/02/2019	SIZE	A
FRACTIONAL	± 1/64	CHECKED		FSCM NO.	
		DESIGN		DWG NO.	HIB3457 WM
		MATERIAL		SCALE	
				PLOT SCALE	
				SHEET	1 OF 1
				FILE	HIB3457WM.pdf
				DRAWING NOT TO SCALE	