

PART NO.	BASE TYPE	DESIGN VOLTS	DESIGN WATTS	DESIGN AMPS	MSCP	FILAMENT TYPE	AVERAGE LIFE HOURS
XPR3	S.C. MINIATURE FLANGED P13.5s	3.6	3.1	0.85 ±10%	3.3 ±15%	C-2R	40

REVISIONS			
REV	DESCRIPTION	DATE	APPROVED
1	ISSUED	02/23/2004	D.C.
2	REVISED MOL, GDIA DIMENSIONS	07/11/2012	D.C.

RoHS COMPLIANT
LEAD FREE

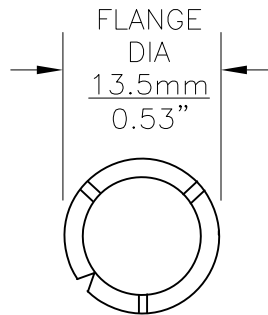

TOP VIEW

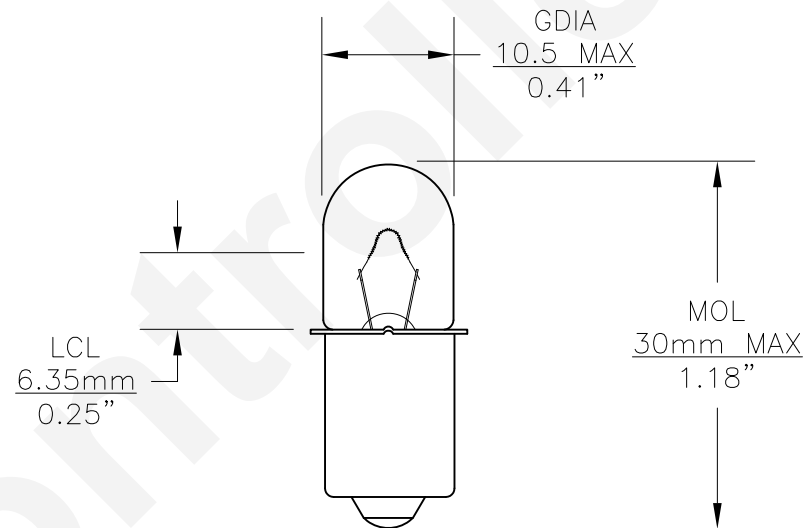

UNLESS OTHERWISE SPECIFIED: DIMENSIONS ARE IN INCHES TOLERANCES		CEC INDUSTRIES LTD			
DECIMALS .XX ± .05 .XXX ± .010 FRACTIONAL ±1/64		599 BOND STREET		LINCOLNSHIRE, IL 60069	
DRAWN Anna Soloveychik		DATE 02/23/2004		TITLE LIGHT BULB NO. XPR3, XENON	
CHECKED	DESIGN	SIZE A	FSCM NO.	DWG NO. XPR3	REV 2
MATERIAL		SCALE	PLOT SCALE	SHEET 1 OF 1	
		FILE XPR3.dwg	DO NOT SCALE DRAWING		